

The 2S-1 Pump Controller



Oil & Gas Instruments, Inc.

Copyright © 2000. All Rights Reserved

Oil & Gas Instruments' 2S-1 Technical Overview

The 2S-1 represents a 2-speed (ON/OFF, HIGH/LOW) version of the VS-1 *Variable Speed Controller*, operating by way of a standard open/closed relay rather than 4-20 mA out. The 2S-1 optimizes production by operating a well only when enough fluid is available to justify extraction, protecting against loss of flow at the pump. Like the VS-1, it is completely surface mounted and fits all pump types. Because of its fine measuring resolution, it is extremely suitable to PC or ESP gas wells under waterflood. Can be converted to VS-1 and vice versa.

The 2S-1 has no moving parts. Instead, it operates on a principle of thermal cooling. Both of the 2S-1's stainless steel probes measure temperature. That is, each one acts independently as a separate, high-precision thermometer. In addition, one of the probes is supplied with a heating coil. When the coil is turned ON, the tip of the probe is heated. This heat is absorbed by passing fluid: the higher the flow, the more heat absorbed, and the greater the cooling at the heated tip. By comparing how the temperature at the heated probe is changing up and down relative to the unheated probe, the 2S-1 can accurately measure changes in flow past its tips over time.

It is worth remarking that gas absorbs heat at much lower rate than either oil or water. Even fast moving gas cools much less effectively than slow moving oil and water. This makes it easy to distinguish between gas and liquid in the flowline, a problem often affecting other flow measurement devices such as turbine meters and orifice plates.

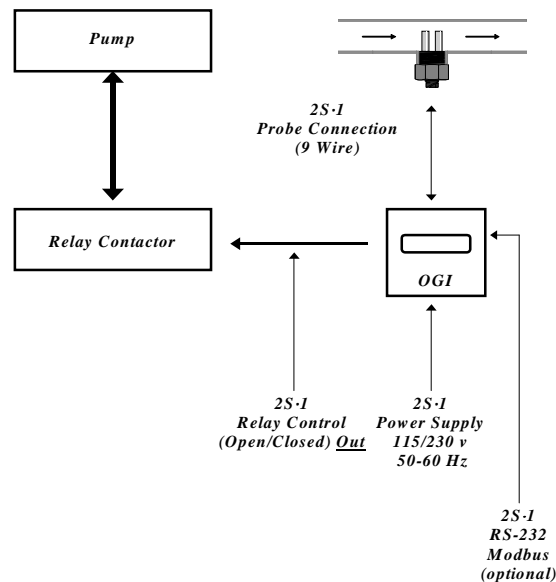

Easy to Install

The 2S-1 probe is installed into a standard 2" NPT close to the wellhead. It is fitted with a 1" thread above a 2.5" × 1.5" hexagonal base and so plumbing requires only a pipewrench.

2S-1 Process Control

The 2S-1 is an auto-calibrating instrument. Once installed and powered on, it immediately begins controlling a well. The 2S-1 follows a simple four step cycle. The four steps are called: (1) *Min. Test*, (2) *Max. Test*, (3) *Regulate*, and (4) *Idle*. The first two steps (*Min. Test* & *Max. Test*) perform the auto-calibration. During Step 3: *Regulate*, the 2S-1 simply monitors ongoing flow waiting for a pumpoff to occur. Once *Step 4: Idle* is reached, the pump is stopped, idling the well, giving time for the wellbore to refill. The length of time the well is idled can be easily adjusted up or down via the instrument's front panel keypad and display. By default, the idle is set to 30 minutes.

The table below shows the order of each step, pump setting (ON or OFF), and default time spent at each:

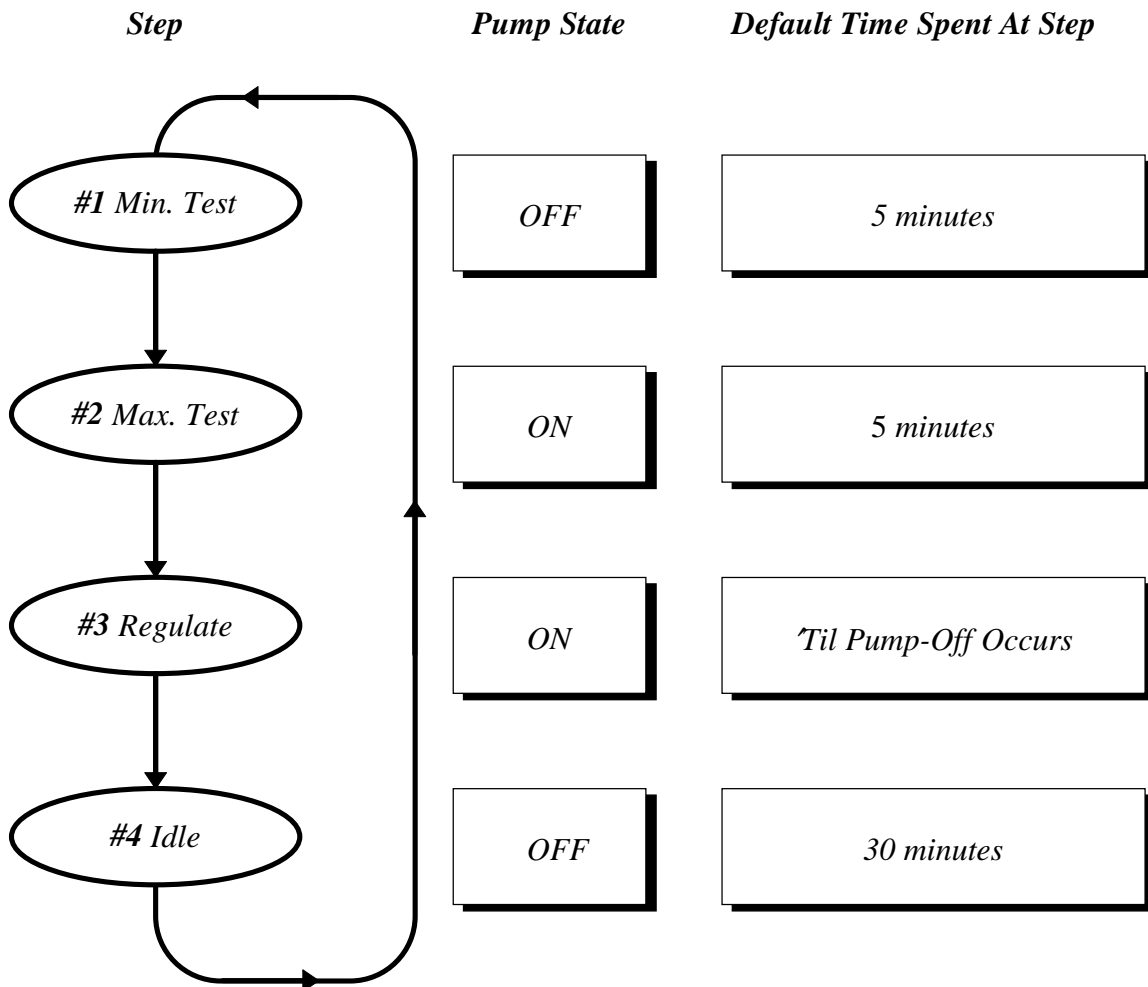

Bells & Whistles

- ***Cold Alarm***

To prevent freeze-up during winter months, the 2S-1 contains a *cold alarm*. Whenever the pump is turned OFF, the 2S-1 continues to monitor the ambient temperature of the gas or fluid inside the flowline. If the temperature drops too far, the pump is automatically re-started. The cold alarm can be set to between -10°C and +5°C (14°F to 41°F). With this option, an operator does not have to track temperature forecasts, reduce pump idle times, or otherwise manually override pump control to accommodate winter conditions.

- ***Scale Resistant***

The 2S-1 probes are constructed of stainless steel having a finely polished surface. A by-product of the heat radiated by the heating coil is to minimize the buildup of wax and other residue on the surface of the probe. In practice, both tips of the 2S-1 contain heating coils, however only one is ever turned ON at a time. Whenever the pump is re-started after idling the well, the roles of the two probes are reversed: the ambient probe assumes the role of heated probe and vice versa. By reversing the roles of the two probes in this way, both are kept free of scale due to paraffin, etc. over time.

- ***Automatic Staggered Start-Up***

Power utilities in many jurisdictions charge by peak demand in their electrical billings. This can put a well operator at a disadvantage if multiple sites operate from the same power grid where power outages are common (e.g. one or more per billing period). When power is restored, all wells draw current simultaneously, leading to large, errant power spikes and artificially high demand charges.

The 2S-1 easily overcomes this problem. Each time power is supplied to the instrument, a random number of seconds, between 0 and 60, is added to the start-up time before the 2S-1 actually turns ON the pump. In this way, start-ups at individual wells are automatically staggered, and wells within the same power grid are brought online in intervals minimizing demand overhead.

- ***Modbus RTU***

The 2S-1 contains an RS-232 interface compatible with the Modbus RTU protocol for remote communication and other SCADA requirements.

Technical Specifications

- Power: 115/230v, 50-60 Hz, ½ Ampere
- Probe Temperature Operating Range: -10°C to +180°C
- Probe Dimensions: 1" Thread; 2.5" × 1.5" Hexagonal Base
- Probe (Tip) Length Above Thread: 4 cm
- NEMA-4x Rubber Gasket, Universal Key, Double-Panel Steel Enclosure
- Enclosure Dimensions: 30cm × 30cm × 15cm
- 5 Status LEDs, 4 × 40 LCD Backlit Display, 8 Command Keys
- Environmental Operating Range: -40°C to +85°C
- 4-20 mA A/D, D/A Signaling
- Solid State Relay (2 Amp, 240v AC Out)
- Modbus RTU Compatible (RS-232)
- ½ Amp SloBlo Fuse Protection
- CSA Class I, Division 2 Approved
- ISO-9001 Manufacturing

Oil & Gas Instruments, Inc.
Phone# : (519) 287-3554
E-Mail : ogi@ogi.net
Fax : (519) 287-5159
Web Site : www.ogi.net